

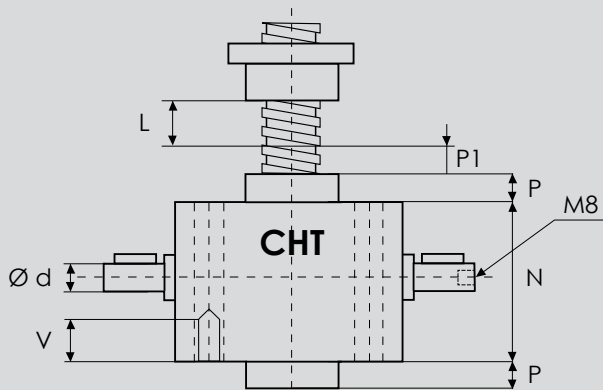

# СЕРИИ CHS 5 RS · ВРАЩАЮЩИЙСЯ ВИНТ

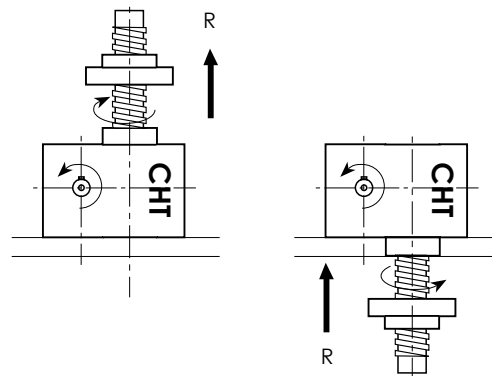

L = ПРОБЕГ

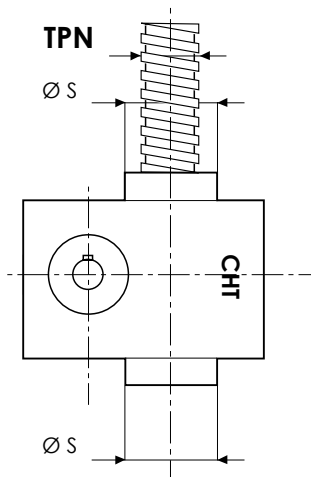
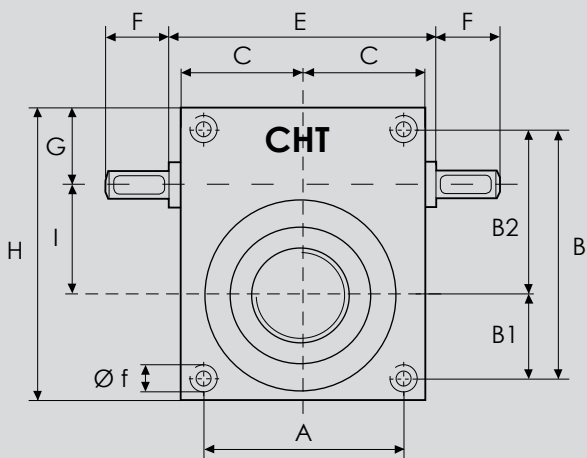

## АДАПТЕР МОТОРА КОРОТКОГО ФЛАНЦА

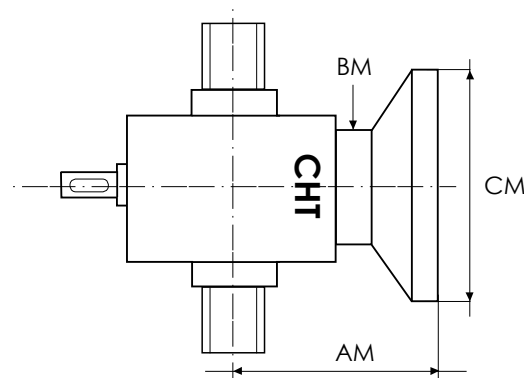

МОТОР	ФЛАНЦЕВЫЙ ТИП	CM	AM	BM
GR. 80	B5	200	140	108
	B14	120		
GR. 90	B5	200	140	108
	B14	140		
GR. 100/112	B5	250	140	108
	B14	160		

### КОНФИГУРАЦИЯ

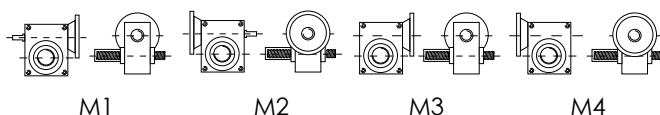

## БРОНЗОВАЯ ГАЙКА

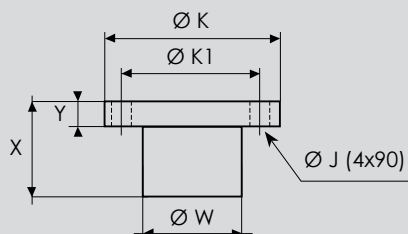

	X	Y	ØW	ØK	ØK1	ØJ
CHS5	100	20	76	130	100	13